



new
energy
for the future

FOREWORD

NEW ENERGY FOR THE FUTURE

Staunchly committed to energy and ecological transition, Nantes - Saint Nazaire Port has begun to change its economic model, which historically speaking has been based on fossil-energy-generated maritime traffic. The first concrete results of the ambitious strategy that we adopted in 2021 are already clearly apparent.

2022 will undeniably remain in the memory as the year in which France's first ever offshore wind farm came on stream: a carefully prepared industrial and logistical achievement that mobilized all the expertise of the Loire Estuary's port professionals. This success means that we can now look forward to the next stages, which are essential to France's future energy mix, and include the ambitious challenge of floating wind power generation.

This dynamic is the product of a team spirit that is to be found in Oportunity, Greater Western France's port promotion collective, which was launched last year. The aim of that initiative is to mobilize and to unite all our energies so as to create new energy sources, to the benefit of the entire Regional Community.

Christelle Morançais
Chair of the Supervisory Board

Olivier Trétout
Chair of the Management Board



At the launch event for Oportunity, Greater Western France's port promotion collective.

CONTENTS

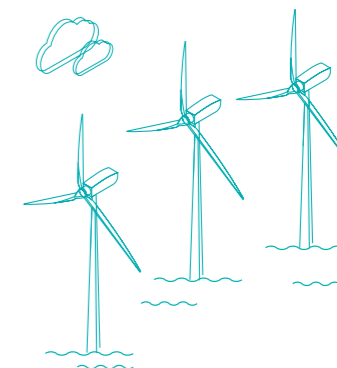

Part 1 - An Industrial Tool for Economic Growth

Nantes – Saint Nazaire Port Markers	6
Serving Sustainable Public Planning and Development Policies	8
Complementary Governance Bodies	10

Part 2 - 2022 Annual Report

Significant Events	14
Key Issues	20
1 - Contributing to the Deployment of the Offshore Wind Power Sector	21
2 - The New Policy to Value-Enhance Port Authority Real Estate	22
3 - Developing the Commercial Port	24
Traffic Areas at the Heart of National and International Energy-Related Challenges	26
Performance Indicators	28
Economic and Financial Indicators	30

Part 3 - 2022 CSR* Report

Maintaining Dialogue with Interested Parties	34
1 - Industrial Relations Dialogue	35
2 - Economic and Institutional Players	36
3 - Environmental Interest Groups and the Scientific Community	40
4 - Connecting with the Community and the General Public	42
Working to Support Employment and Professional Equality	44
Acting to Advance Energy Transition	46
Managing the Loire Estuary's Natural Spaces	50
CSR Indicators	52

* Corporate Social Responsibility

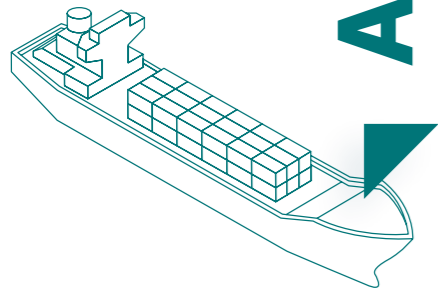

AN INDUSTRIAL TOOL

FOR ECONOMIC GROWTH



NANTES - SAINT NAZAIRE PORT MARKERS

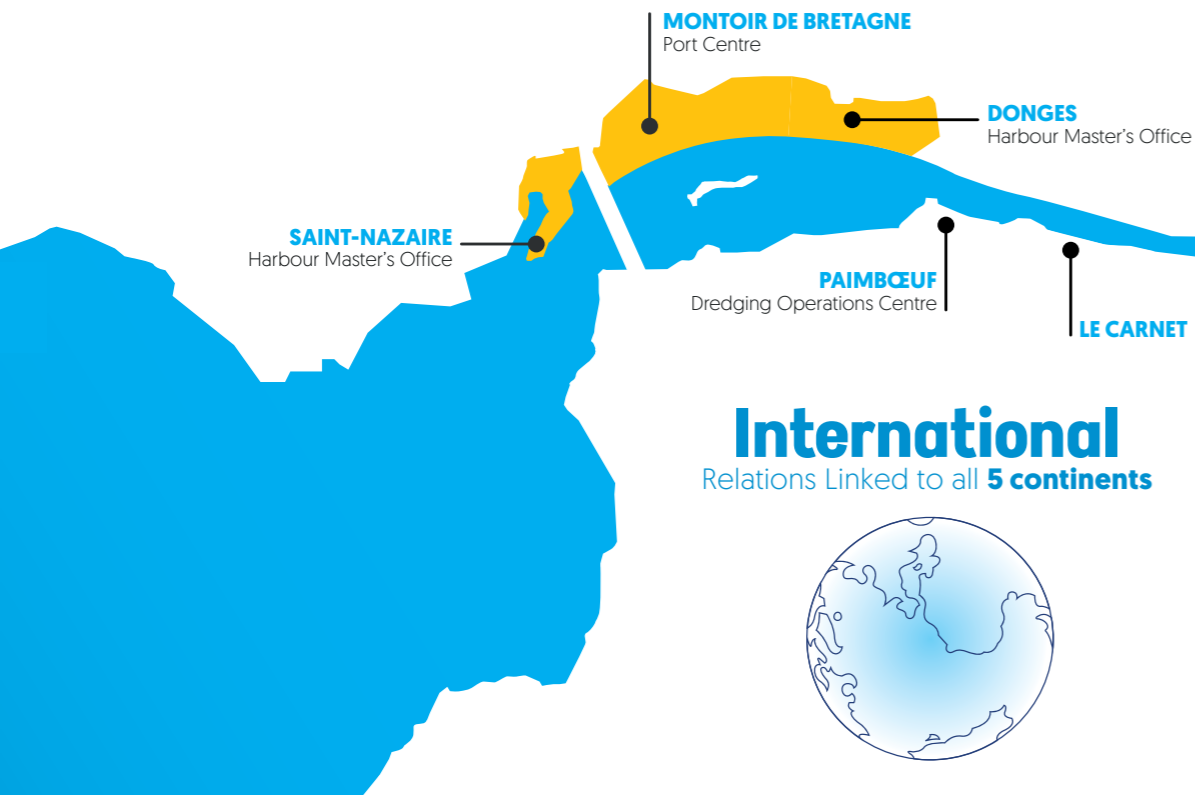

2 504
calls by merchant vessels

Nearly **730**
goods trains

254
inland waterway
barge convoys

TRAFFIC

Over **300** types of cargo each year

EMPLOYMENT

The activities at the Port of Nantes – Saint Nazaire generate:

28 500 jobs*

*2022 study by INSEE, the French National Institute of Economic and Statistical Information, based on 2018 data.

and **19 500**
industrial and
service sector jobs

of which **9 000**
maritime and
port-based jobs

604
salaried
employees
nearly
80
specialisms



CORDEMAIS

LE PELLERIN
"Les Coteaux" Workshops

NANTES
NANTES SAINT-NAZAIRE PORT
HEADQUARTER
"Salorges" Centre

UPRIVER
PORT FACILITIES

CHEVIRÉ
Harbour Master's Office

DOMAINE

Port Authority Area

2 722 hectares

including

1 460 hectares of developed port, logistical and industrial zones

1 177 hectares of natural spaces

25 hectares available for development

60 hectares in urban areas

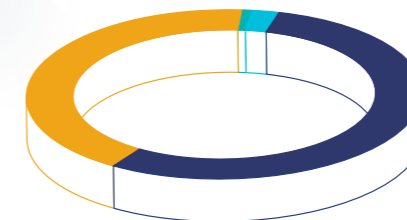

SERVING SUSTAINABLE PUBLIC PLANNING AND DEVELOPMENT POLICIES



The Nantes port facilities.

Nantes – Saint Nazaire Port is a public enterprise corporation in which the State is the sole shareholder. The Port Authority is charged with implementing public policies on sustainable planning and development, while managing compromises between economic, employment and environmental concerns. It is entrusted with several missions: the provision, operation and maintenance of maritime accesses, policing, safety and security, the value enhancement of Port Authority real estate, the conservation of natural spaces, the construction and maintenance of infrastructures, the promotion of rail and inland waterway service provisions, the development and management of industrial and logistical activity zones, and general promotion.

An industrial facility forming the interface between land and sea, Nantes – Saint Nazaire Port fulfils a dual role, as an accelerator of Regional Community economic development and as an integrator of industrial and port-related activities within the urban and natural environment. The Port Authority works in partnership with Greater Western France's other public-sector stakeholders (Central, Regional and Local Government bodies, consular organizations, etc.) and private-sector stakeholders (industrial and port firms, logistics companies, shippers and so on).

The developed sites represent
a total surface area of

1545 hectares

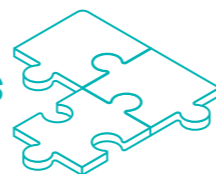

Already developed sites and those being developed for future activities represent a total surface area of 1545 hectares, which include 25 hectares available for development and 60 hectares in urban areas. The port areas, including terminals, logistical facilities, and industrial premises, are linked up to the national road and rail networks. They are also located close to the airports in Nantes and at Montoir de Bretagne. An inland waterway link is provided on the Loire Estuary for different types of traffic.

For container traffic, the Port has direct liner services to the French West Indies and the West Coast of Africa. In addition, several feeder services are connected to the main transshipment hubs in Northern Europe and in Southern Spain, thereby linking Nantes – Saint Nazaire to all five continents. Regular ro-ro services are provided to and from Northern Europe (Germany and Belgium), the Iberian Peninsula (Spain), the Mediterranean (Morocco, Tunisia, and Italy), and the USA (Alabama).

For importing and exporting companies in the regions of Greater Western France, Nantes – Saint Nazaire Port makes available doorstep services that serve to optimize supply and distribution chains. For all types of traffic, the Port proposes an added-value logistical service offer (notably warehousing, packing into bags, and order preparation) and a statutory service offer (including customs, veterinary services, and phytosanitary services). The Port of Nantes – Saint Nazaire is a classified Border Inspection Point (BIP), a classified European Union Point of Entry (EUPOE) and a classified Designated Point of Entry (DPOE), which notably permits plants and cattle feed from other countries to be introduced into the territory of the European Union.



The Saint Nazaire port facility and the mouth of the Loire Estuary.

COMPLEMENTARY GOVERNANCE BODIES

The governance of Nantes – Saint Nazaire Port is built around consultative and decision-making bodies.

The Supervisory Board decides on Nantes – Saint Nazaire Port’s strategic orientations and exercises ongoing control over its management. It is able to rely on the work of the Development Board and of the Loire Estuary Scientific Board. Headed by Christelle Morançais, the Chair of Pays de la Loire Regional Council, the Supervisory Board is made up of 18 members, who include Central Government representatives, representatives of Regional and Local Government, salaried employees of the Port Authority and qualified figures. David Samzun, the Chair of Saint Nazaire Urban Area District Authority and Mayor of Saint Nazaire, is the Vice-Chair of this

Governance Body. The Supervisory Board met on four occasions in 2022. It discussed or deliberated upon different subjects, which included the development of a logistics-oriented real-estate offer for the Montoir de Bretagne industrial platform and the conditions for the operation of port plant and equipment at the Nantes port facilities.



Pascal Fréneau, Olivier Trétout and Julien Dujardin.

The Management Board is charged with the executive management and administration of Nantes – Saint Nazaire Port. This Governance Body has three members: Olivier Trétout, who is the Chair of the Management Board, Julien Dujardin, Deputy Managing Director responsible for technical resources, and Pascal Fréneau, Deputy Managing Director responsible for functional resources.

The Development Board is a body that is representative of civil society and a forum for discussion and exchange. Its 32 members are divided into 4 colleges: Port Community representatives, Port Community personnel representatives, Local and Regional Government representatives, and qualified figures. Chaired by Bruno Michel, the Director of the Elengy LNG terminal at Montoir de Bretagne, the Development Board held four meetings in 2022, at which various subjects were discussed; these included the latest developments in the ports sector, the project



to provide an integration base for floating wind power in Saint Nazaire, and the plan for a low-carbon industrial activity zone [ZIBaC].

Placed under the authority of the Regional Prefect, the Loire Estuary Scientific Board is made up of 16 qualified figures appointed on account of their scientific expertise. This Governance Body is chaired by Mario Lepage, of the French National Institute of Science and Technology for the Environment and Agriculture. The Loire Estuary Scientific Board met on one occasion in 2022, to discuss in particular the proposed revision of the Water Planning and Management Scheme [SAGE] for the Loire Estuary.

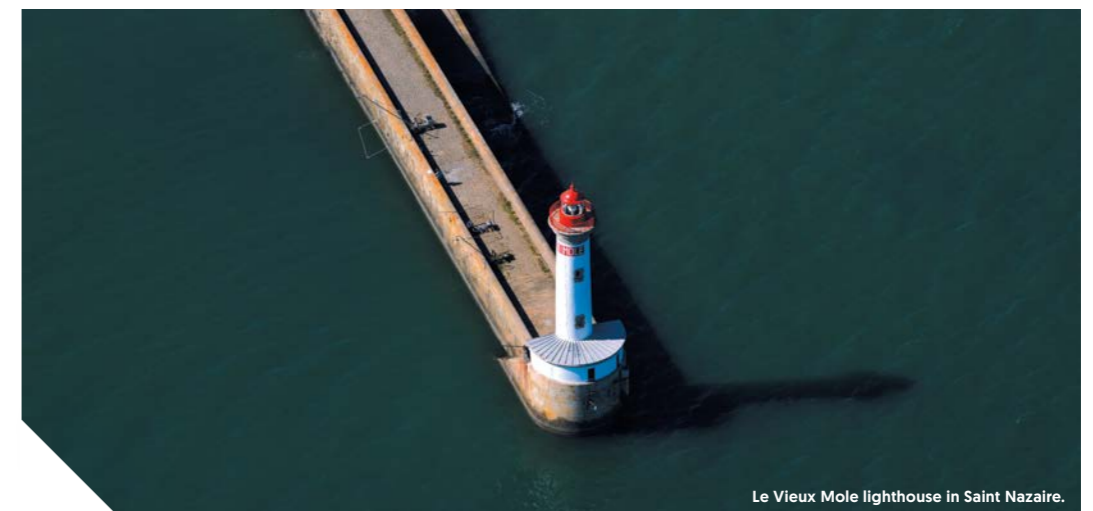



▼ ANNUAL REPORT

2022



SIGNIFICANT EVENTS

JANUARY – FEBRUARY – MARCH

JANUARY > MAY

In a project funded within the framework of the Economic Recovery Plan, 3.6 kilometres of railway tracks comprising the Le Priory rail facility, the exchange point between the national rail network and the Montoir de Bretagne port terminals, formed the subject of a renewal programme conducted between late January and May.

FEBRUARY

Saw the start of work to increase the capacity of the Montoir de Bretagne liquid cargo berth, through the creation of two new landing stages.

MARCH

In conjunction with Saint Nazaire City Council and the Urban Planning Agency for the Saint Nazaire Area, Nantes - Saint Nazaire Port initiated a consultation with a view to appointing an urban project manager for the plan to develop the Petit Maroc area of the City.

13th MARCH

Commencing in March, work was carried out to upgrade the network of electrical power points at the Quai des Darses and Quai des Charbonniers quays in Saint Nazaire, with a view to improving the level of service and to offer the quality of facilities necessary for existing and future industrial activities.

15th MARCH

A delegation from the Port of Nantes - Saint Nazaire took part in a visit organized by Pays de la Loire Regional Authority to the Port of Antwerp, so as to understand the specificities and the dynamics present at Europe's second largest port.

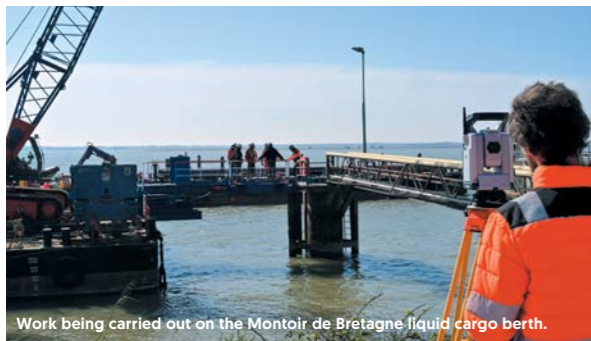

Work being carried out on the Montoir de Bretagne liquid cargo berth.

APRIL – MAY – JUNE

1st APRIL

The first wind turbines for the Saint Nazaire offshore wind farm were loaded aboard the installation vessel *Vole au Vent*, at the Joubert sluice dock.

IN MID-APRIL

Nantes - Saint Nazaire Port launched a third online pathway to discovering the Loire Estuary, entitled "A Bird's Eye View of the Estuary", which has an augmented-reality feature.

AT THE END OF APRIL

The forces refuelling vessel *Jacques Chevalier* arrived at the Quai de la Prise d'Eau facility in Saint Nazaire for a fitting-out operation, with the unoccupied section of the quay being reserved for cargo handling activities.

EARLY IN MAY

After an 18-month-long hiatus, the TotalEnergies oil facility at Donges restarted its refining activities.

3rd MAY

Construction work started on a 3 000 m² building at Montoir de Bretagne's East Platform, for TGO, the operator of the general cargo and container terminal located very close by.

FROM 7th TO 17th JUNE

Nantes - Saint Nazaire Port welcomed port management personnel from ports in West and Central Africa for a training session as part of UNCTAD's TrainForTrade Programme.



AT THE END OF JUNE

The European Commission approved the study co-financing application submitted by Nantes - Saint Nazaire Port in January regarding the Éole project for a floating wind power integration base. An agreement was subsequently signed in October, within the framework of the Connecting Europe Facility (CEF) programme.

JULY – AUGUST – SEPTEMBER

4th JULY

Co-chaired by the Chair of Pays de la Loire Regional Council and Head of the Port Authority's Supervisory Board, and by the Prefect for the Pays de la Loire Region, the steering committee for the Éole project was installed.

IN JULY

Following a CEI, Nantes - Saint Nazaire Port signed an agreement with Amarengo for the installation of a 13.9-hectare ground-level photovoltaic power plant at Montoir de Bretagne.

EARLY IN AUGUST

In Saint Nazaire, work commenced on the railway line serving the Idéa and Cargill plants. The aim of the renewal work is to replace the ballast, sleepers and points, and to install decking. These operations are co-financed within the framework of the 2015-2022 Central Government – Regional Government Planning Agreement.

25th AUGUST

Nantes - Saint Nazaire Port published a call for expressions of interest (CEI) in the construction of controlled-temperature warehousing in the Montoir de Bretagne industrial and port activity zone, with a view to delivering a response to the significant requirements expressed, notably in the agri-food sector, and to help strengthen the shipping service offer.

AT THE END OF AUGUST

Earthmoving work on a 4800 m² area of the Montoir de Bretagne ro-ro terminal was completed, with the provision of an electricity delivery point permitting the installation of motor vehicle charging stations.

SEPTEMBER

A CEI was issued with a view to appointing an economic operator capable of developing a real-estate project on the Quai de l'Aiguillon site, at the location of the current shed N°12, in Nantes.

7th SEPTEMBER

The pre-assembly operations on the 80 wind turbines destined for the Saint Nazaire offshore wind farm were completed, 43 days ahead of EDF's initial schedule.

The 53rd edition of the Solitaire du Figaro single-handed yacht race arrived in Saint Nazaire.

AT THE END OF SEPTEMBER

In the Saint Nazaire dock basins, Lhyfe launched its first offshore renewable hydrogen production prototype, with a capacity of 1 MW.

OCTOBER – NOVEMBER – DECEMBER

ON 13th OCTOBER

With over 120 Loire Estuary economic players in attendance, Greater Western France's port promotion collective revealed its new name: **Opportunity**, thereby giving fresh impetus to the initiative launched by Pays de la Loire Regional Authority, Loire Atlantique Departmental Authority, Nantes Metropolitan District Council, Saint Nazaire Urban Area District Authority, Nantes Ports Maritime Union (UMNP), Nantes - Saint Nazaire Chamber of Commerce and Industry, and Nantes - Saint Nazaire Port.

AT THE END OF OCTOBER

Work on renovating a pile at oil tanker berth N°4 at Donges, which had been severely eroded by the current of the River Loire, was completed.

Work commenced on the in-water overhaul of the caisson gate of dock N°2, in Saint Nazaire.

27th AND 28th OCTOBER

Nantes - Saint Nazaire Port opened its doors to the general public on the occasion of the Pays de la Loire Region's 7th annual "Company Tours in Our Region Days" initiative.

8th NOVEMBER

Nantes - Saint Nazaire Port validated a technical and financial proposal from RTE permitting studies to begin regarding the connection of power supply to a plot of land in the Montoir de Bretagne industrial and port activity zone, representing a capacity of 250 megawatts.

15th NOVEMBER

The Loire Estuary Association of Industrial Firms (AILE), Saint Nazaire Urban Area District Authority, Estuaire et Sillon Community District Authority and Nantes - Saint Nazaire Port submitted an application in response to the call for proposals by ADEME (the French National Agency for Energy Transition) for a low-carbon industrial activity zone.

MID-NOVEMBER

Nantes - Saint Nazaire Port and Lhyfe, one of the world's pioneers for the production of green, renewable hydrogen, signed a partnership agreement to develop the offshore renewable hydrogen sector.

A partnership agreement between Lhyfe and Nantes - Saint Nazaire Port.



OCTOBRE – NOVEMBRE – DÉCEMBRE

FROM 20th TO 25th NOVEMBER

Nantes - Saint Nazaire Port took part in a Pays de la Loire Regional Authority-organized mission to Scandinavia, focussing on issues that notably included the decarbonization of ports and offshore wind power.

FROM 22nd TO 24th NOVEMBER

Following Season 1, which successfully delivered several digital solutions, Nantes - Saint Nazaire Port's Smart Port Hackathon made a return, to the Halle 6 Technology Centre in the Île de Nantes District of Nantes.

21st NOVEMBER

Nantes - Saint Nazaire Port issued a CEI for the provision of industrial capacity for the production of low-carbon hydrogen in the Montoir de Bretagne port area.

23rd NOVEMBER

Saw the official inauguration of France's first offshore wind farm facility, which is sited off Saint Nazaire.

13th DECEMBER

Greater Western France's port promotion collective held its first roadshow event in Angers, in partnership with the Maine et Loire Chamber of Commerce and Industry.

31st DECEMBER

Subsidiary company Nantes Port Terminal, which had been running the Chevire port facility, ceased operation. As of 1st January 2023, the facility is now directly operated by Nantes - Saint Nazaire Port.



During the installation of the Saint Nazaire offshore wind farm.



At the close of the Smart Port Hackathon.

KEY ISSUES



Wind turbine masts being loaded aboard the offshore installation vessel *Vole au Vent*.

Nantes - Saint Nazaire Port is committed to energy and ecological transition. On 3rd December 2021, the Port Authority adopted a strategic plan for the period 2021-2026, which is articulated around three major objectives:

- delivering successful energy and ecological transition;
- consolidating the Port's role as the maritime gateway to Greater Western France;
- serving the economic and social development of the Loire Estuary.

The 2021-2026 strategic plan is an important stage in the construction of Nantes - Saint Nazaire Port's new economic model. To offset the decrease in fossil energy activities, there is a focus on activating new growth drivers, including the conduct of real-estate projects for the logistics and tertiary sectors, and the completion of studies relating to the emerging offshore floating wind turbine sector. Actions are also being undertaken to promote the growth of bulk cargo and general cargo traffic, including containers and ro-ro, to the benefit of firms and companies in Greater Western France.

A 2021-2026 strategic plan committed to energy and ecological transition



1 - Contributing to the Deployment of the Offshore Wind Power Sector

In 2022, Nantes Saint Nazaire Port actively participated in the development of the marine renewable energy sector, and anticipated the upcoming stages in the process of accommodating the future generations of offshore wind farms.

France's first offshore wind farm, which is sited off Saint Nazaire and was officially inaugurated on 23rd November, delivered on more than 10 years of commitment and investments by Regional Community players to promote the growth of this sector.

The port facilities at Montoir de Bretagne and in Saint Nazaire have been the theatre of some delicate and spectacular logistical and port-based operations over the past two years, requiring the unerring commitment of Port Community professionals and all their know-how. The highlight was the campaign of wind turbine installation operations for the wind farm facility sited off Saint Nazaire, which took place between April and September. The offshore installation jack-up vessel *Vole au Vent* completed some twenty rotations to transport the wind turbine components to the offshore site. This great logistical and human achievement resulted in a volume of traffic estimated at 100 000 tonnes of wind turbine components and in 120 port calls in 2022. The 80 wind turbines have been in operation since the end of 2022 and are set to provide enough power to cover 20 % of the electricity consumption of the Department of Loire Atlantique.

Building on this first successful experience, Nantes - Saint Nazaire Port and the entire Port Community have put themselves forward to participate in the deployment of a second offshore wind farm facility, to be sited off the islands of Île d'Yeu and Noirmoutier. The Company Éoliennes en Mer Îles d'Yeu et de Noirmoutier (EMYN) will be installing 62 wind turbines on the site, representing an annual output of 1900 GWh, or the equivalent of the annual consumption of 800 000 people.

A new energy mix is to be permanently established by 2050, incorporating notably offshore wind power generation on a larger scale. Nantes - Saint Nazaire Port wishes to anticipate the massive development of floating wind power, which is going to require specific port infrastructures. The Port Authority is aiming to place at the disposal of the offshore sector a dedicated industrial integration base for floating wind turbines. The Éole project consists in redimensioning the existing infrastructure, namely the pre-assembly facility in Saint Nazaire, so as to meet the requirements of the sector's industrial firms.

Nantes - Saint Nazaire Port is designing a new port infrastructure in order to make it possible to receive such XXL components. In this way, at this stage of the studies, the integration base should offer approximately 700 metres of quay, reinforced to bear over 30 tonnes per m², a draught of 12 to 14 metres, more than 300 metres of overhead clearance, XXL plant and equipment to handle consignments weighing several thousands of tonnes, and a reception berth for the floats. The offshore and onshore geotechnical studies commenced in January 2023. These studies will serve to identify the characteristics of the site and to draw up an initial assessment that can be used to inform the thinking regarding the geometry of the Éole project's structural elements, the characteristics of the foundations, and the methodologies and volumes of work to be considered.

A major project for the future of the Regional Community, supported at local, national and European level, the Éole project has its own steering committee, which was installed on 4th July 2022 and is co-chaired by the Chair of Pays de la Loire Regional Council and Head of the Port Authority's Supervisory Board, and by the Prefect for the Pays de la Loire Region.

2 - The New Policy to Value-Enhance Port Authority Real Estate

The value enhancement of Port Authority real estate and the conduct of real-estate projects for the logistics and tertiary sectors are among the growth drivers identified in the 2021-2026 strategic plan. This source of income should make it possible to construct a new economic model that is less reliant on fossil-energy-related maritime traffic. Numerous projects came to fruition or were undertaken in 2022.

The programme to develop a “plug & play” logistical real-estate offer at the Montoir de Bretagne industrial operations facility continued in 2022. Offering storage solutions has become a major economic factor, in response both to a Regional Community logistical real-estate market that is feeling the strain, and to the requirements of a variety of sectors of activity (the aeronautical, agri-food, and marine renewable energy sectors, shipbuilding, mass retailing...), which generate multiple supply chains calling for storage capacity.

A new 3000 m² metal-and-textile warehouse was built in just a few weeks in May, to the north of the container terminal. The keys were handed over at the start of June to Terminal du Grand Ouest (TGO), the building’s operator and the operator of the general cargo and container terminal. As its logistics business expands, TGO has expressed the need for a second building, to be similar to the first. The preparation work on the plot of land was carried out in the first quarter of 2023.

Construction work on three additional warehouses representing a total surface area of 17000 m² was undertaken at the West Logistics Platform, on a site located at the foot of the Pont de Saint-Nazaire bridge, in order to meet the needs of the marine renewable energy (MRE) sector. Close by, Nantes - Saint Nazaire Port continued work on developing the “plug & play” logistics platform, with the preparation of paved areas on a 9-hectare surface area. The pre-loading work began in November 2022. At the same time, a call for expressions of interest was issued in August so as to develop controlled-temperature storage capacity at the East Logistics Platform. The project will deliver a response to the requirements that have been detected by Nantes - Saint Nazaire Port among firms and companies in the hinterland, most notably in the agri-food sector, and to expand the shipping service offer into and out of Montoir de Bretagne. Further development work is also scheduled in 2023 at that same platform, on a 6-hectare surface area, to accommodate dry storage facilities and industrial logistics warehousing.



In urban areas, Nantes - Saint Nazaire Port is seeking to breathe new life into old port facilities located in the heart of the City. In this way, the Quai Marquis d'Aiguillon site, at which is located Shed N°12, beside the River Loire, halfway between the rapidly changing Bas-Chantenay District of the City and the heart of Nantes, formed the subject of a call for expressions of interest in September. Shed N°12 will make way for a new building, which will be exemplary on an environmental level, and which will contribute to the economic development of Bas-Chantenay and to making the most of the Port Authority’s real estate. This CEI attracted much attention, with 16 high-quality applications being submitted. The winning project will be announced in the summer of 2023. Other real-estate development projects are being considered for the Île de Nantes sector of the City.

In Saint Nazaire, Nantes - Saint Nazaire Port is working actively on the redevelopment of the outer harbour and of the Petit Maroc area, with the creation of islands for tertiary activities. The Agency Devillers et Associés has been charged with preparing the pilot study, in conjunction with Saint Nazaire City Council and the Urban Planning Agency for the Saint Nazaire Area (ADDRN). This phase will continue with the launch of an architects’ competition in the course of 2023.



3 - Developing the Commercial Port

In 2022, Nantes - Saint Nazaire Port undertook numerous investments with a view to maintaining and developing the level of performance of its industrial facilities, and thereby serving the Regional Community's businesses. Large-scale work projects were conducted at Montoir de Bretagne and in Saint Nazaire.

At the Montoir de Bretagne multi-bulk terminal, the liquid cargo berth was reconfigured to permit two small-sized vessels to be received at the same time, while retaining the option of receiving large-capacity vessels at the central berth. The facility is used by several industrial firms that import or export different types of liquid bulk cargo, principally vegetable oils, sand, and the raw ingredients for the manufacture of fertilizers. Commenced in March, the nautical work were carried out in phases, one week in two, so as not to disrupt operations, and was completed in September. The work project continued into October, with the completion of work on the construction of the landing stages on which will be installed the handling equipment of the berth's users, then with the installation of the various supply networks and the provision of a new parking area. This improvement will deliver greater flexibility and user friendliness, by dissociating traffic types that were previously handled on a single landing stage. The new configuration aims to assist current and potential users of the facility in their development and in the diversification of supply. The berth has been operational since the spring of 2023.

In an operation co-financed via the Economic Recovery Plan, electrification work was carried out in 2022 on the Quai des Darses and Quai des Charbonniers quays in Saint Nazaire. Conducted between March and October, the work served to regenerate the power point network on these two quays, to increase the level of service so as to offer the facilities required for existing industrial activities, and to assist in decarbonizing port-related activities. The work consisted in installing a 1 MW transformer plant permitting the distribution of networks of high- and low-voltage power points along the quays, and thereby avoiding the need to employ generator sets. Similar work was carried out on the two new oil tanker pontoons during the summer. The pontoons in the outer harbour in Saint Nazaire were also equipped in the first half of 2023.

Installation of twenty
50 kW.
capacity motor-
vehicle charging
stations.

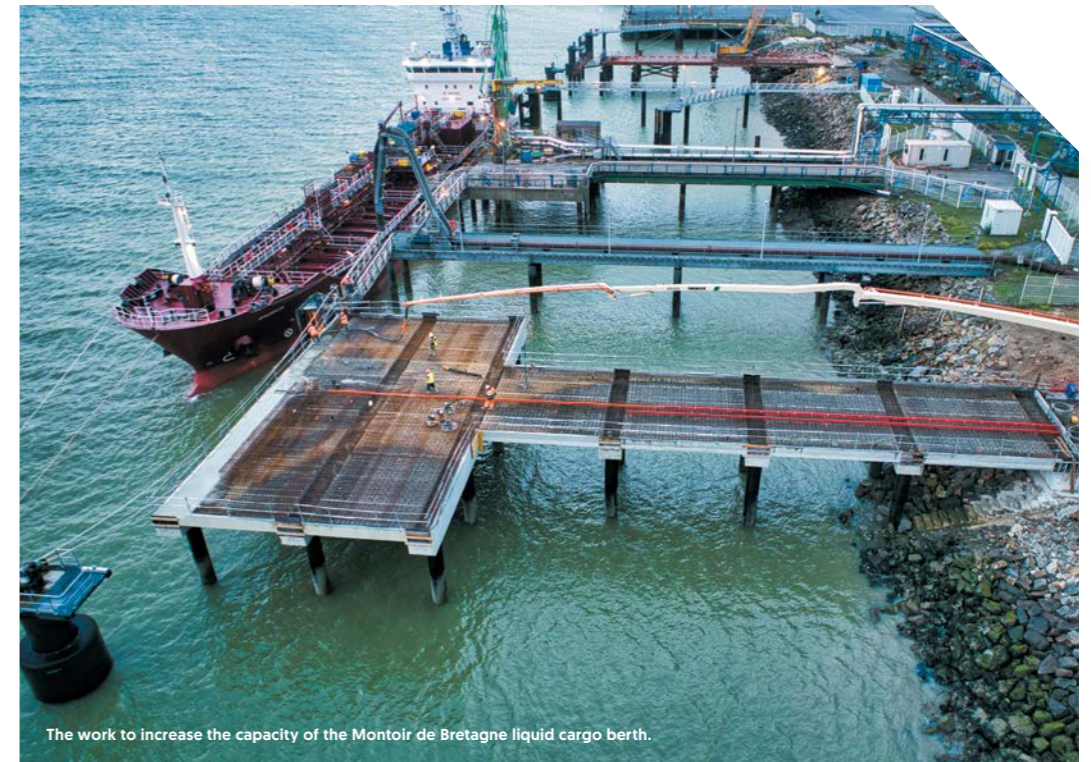
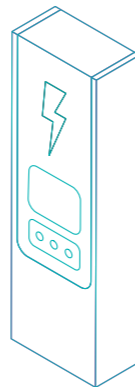

The work to increase the capacity of the Montoir de Bretagne liquid cargo berth.

At Montoir de Bretagne, the ro-ro terminal was equipped with the necessary infrastructures to recharge electric vehicles. This improvement is designed to permit the installation of twenty 50 kW-capacity motor-vehicle charging stations, each of which is able to receive two vehicles at the same time. A 1 kVA electricity delivery point was installed in the course of the summer. Begun in May, the improvement work was completed in August. The installations were made available to a first logistics service provider at the end of the year.

In order to improve the movement of trains on the port-based rail network, work was carried out between January and June to renew the 3.6 kilometres of railway tracks comprising Montoir de Bretagne's Le Priory rail facility. Included in the formalized recovery package in an amendment to the 2015-2020 Central Government – Regional Government Planning Agreement, this operation consisted in packing down the ballast to obtain a better railway track load-bearing capacity, in line

with changing market requirements. In Saint Nazaire, the structures permitting nautical and land access to the industrial and port activity zone have benefitted from a large-scale refurbishment programme over a number of years, and have been the focus of constant attention to ensure that important deadlines are met, as was the case in 2021 and 2022 with the combination of bustling marine industry activity and the deployment of the Saint Nazaire offshore wind farm. Refurbishment work was carried out at the location of the south lock. A major maintenance turnaround began in December on the swing bridge, lasting four months. The work concerned the functional aspects, notably the hydraulic and electric mechanisms. Several maintenance operations were conducted on the Joubert sluice dock, notably in relation to the downstream gate, with the replacement of certain actuators, and at the base of the dock, where civil engineering and metal fabrication work was carried out to protect the culverts.

TRAFFIC AREAS AT THE HEART OF NATIONAL AND INTERNATIONAL ENERGY-RELATED CHALLENGES

The overall traffic level at the Port of Nantes - Saint Nazaire amounted to 29.7 million tonnes (MT) in 2022, 76 % of which was made up of import traffic. This evidences the Port Community's resilience and its ability to gain fresh impetus, in a context marked by considerable geopolitical tensions and by the expected development of energy transition.



The arrival of a liquefied natural gas carrier.

In 2022, the share of energy-related throughput represented more than two thirds (69 %) of the total traffic volume, as opposed to just over half of that figure in 2021 (55 %). This progression was in part the consequence of the worldwide energy crisis. Just like many other countries in Europe, France needed to secure its energy supplies in anticipation of 2022/2023 winter demand. In this way, Montoir de Bretagne's Elengy liquefied natural gas terminal saw its volumes increase very significantly compared to 2021 (+85 %). LNG traffic amounted to 9.9 MT, a level never previously achieved on the Loire Estuary.

In a context of electricity production tension, the EDF thermal power station at Cordemais was also very much in demand in order to meet the electricity requirements of Great Western France. Coal imports thereby progressed by 51 %, reaching a level of 1.2 MT, as compared to 0.8 MT in 2021 and 0.2 MT in 2020.

Hydrocarbon traffic experienced an upswing in 2022, with the progressive restart of operations at the TotalEnergies refinery at Donges following an 18-month-long hiatus. Crude oil imports exceeded 5.1 MT. Refined petroleum products traffic returned to a level that is comparable to the years preceding the closure of the refinery, with less imports (1.8 MT, - 52 %) and more exports (2.4 MT).

2022 was marked by the construction of France's first ever offshore wind farm, which is sited off Saint Nazaire. In terms of figures, this great logistical and human achievement resulted in a volume of traffic estimated at 100 000 tonnes of wind turbine components and in 120 port calls in 2022.

Activity at the container terminal reached a similar level to that achieved the previous year (1.5 MT), being marked by a slight upturn in business in the final quarter, in spite of the disruption to supply chains experienced worldwide impacting the feeder services connected to Montoir de Bretagne. Ro-ro traffic decreased by 11 % compared to 2021. The level of ro-ro traffic was affected by the raw material provisioning difficulties encountered by the Stellantis plant in Vigo, which resulted in the closure of the factory for several weeks. The number of new vehicles thereby amounted to 96 000 units, compared to 109 000 units in 2021. The recovery in the aeronautical sector resulted in a progression in maritime traffic in 2022 (+72 %), notably on the Montoir de Bretagne - Mobile (USA) link, the number of port calls having doubled.

The recovery in agri-food product traffic observed in 2021 was confirmed in 2022, with a 21 % increase. Grain and cereals exports recorded a sharp rise (+80 %, 1.2 MT), on account of the quality of the harvest and of the impact of geopolitical tensions on international markets. Imports of ingredients to be used in the production of animal feed amounted to 2 MT, a level comparable to that achieved in 2021, despite the bird flu pandemic that affected poultry farms across France.

Liquid bulk cargo traffic (excluding energy) attained record levels. In an unprecedented international context, worldwide demand for vegetable oils strengthened. The trituration plants in Saint Nazaire and at Montoir de Bretagne drove this strong progression to a large extent, with over 600 000 tonnes (+31 %) exported to Europe and to other countries. The continued operation of the Montoir de Bretagne liquid cargo berth (whilst work was being carried out to increase the capacity of the dedicated infrastructure) thereby helped to ensure that 440 000 tonnes of rapeseed oil were exported.

Construction-related dry bulk products showed a small increase. Supported by the good volume of activity in the building and civil engineering sector, marine sand stabilized at 1.3 MT, and clinker and cement progressed by 12 %, reaching 358 000 tonnes.

Construction of France's first offshore wind farm.

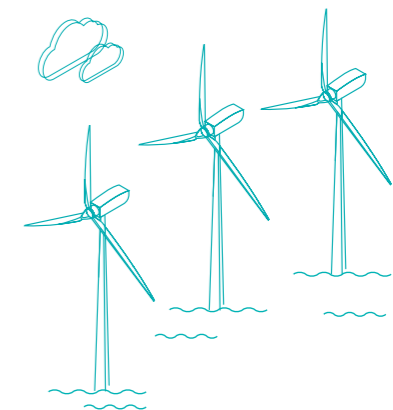

PERFORMANCE INDICATORS

RECEPTION OF VESSELS

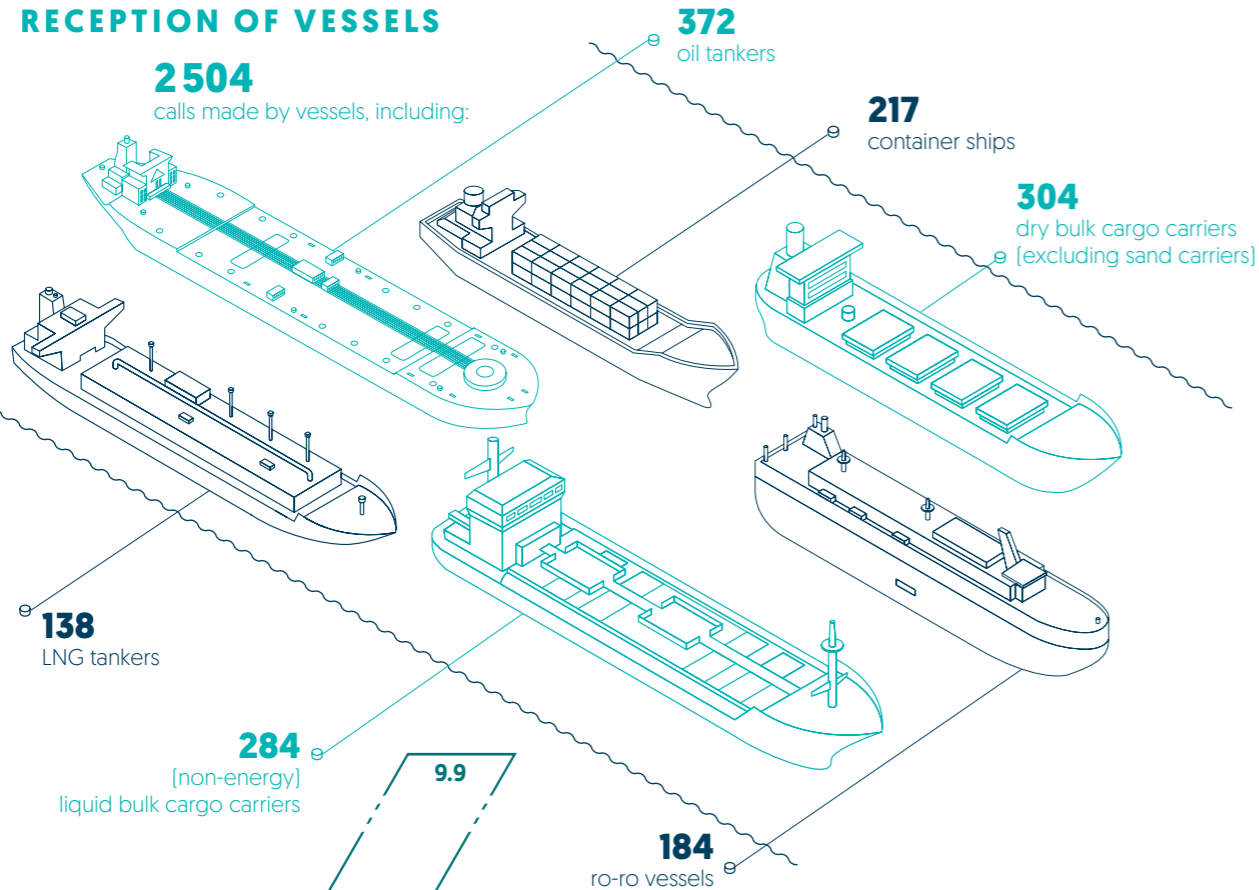

TRAFFIC STATISTICS

(in millions of tonnes)

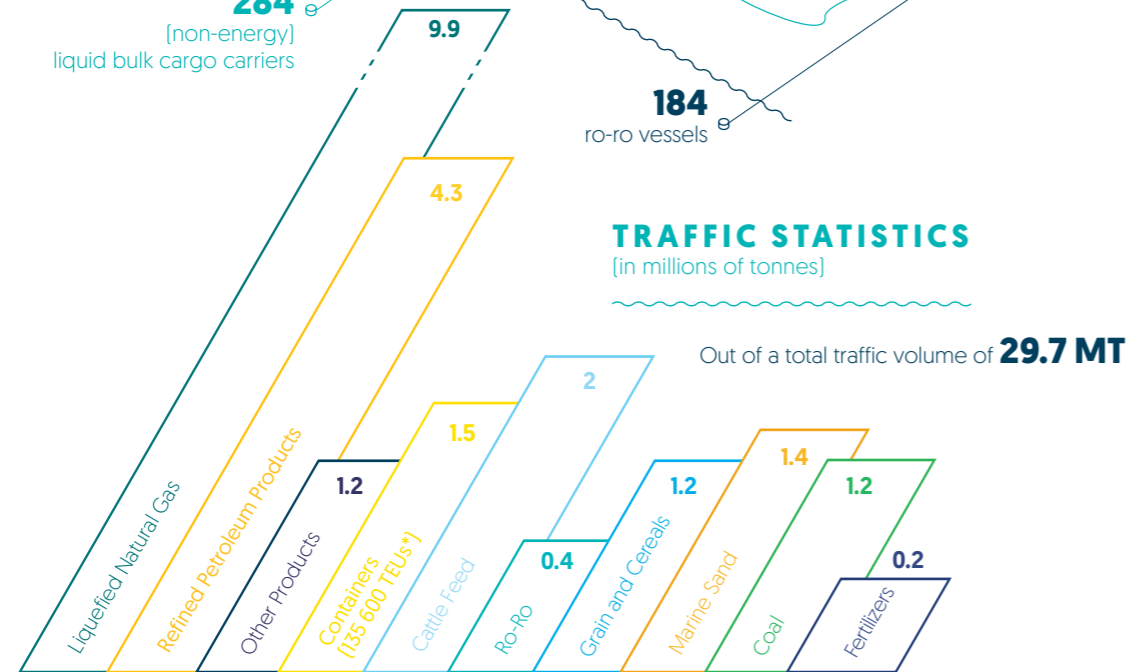

*twenty-foot equivalent units

SHIP REPAIR

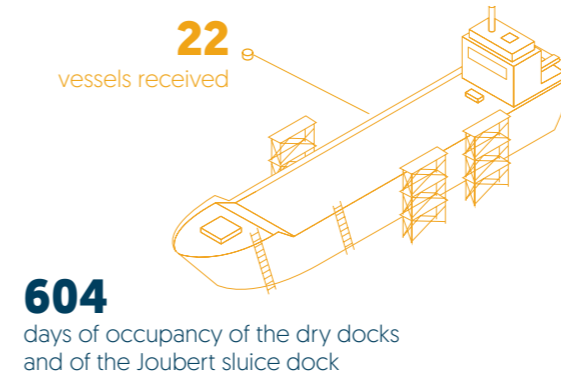

VESSEL SERVICES

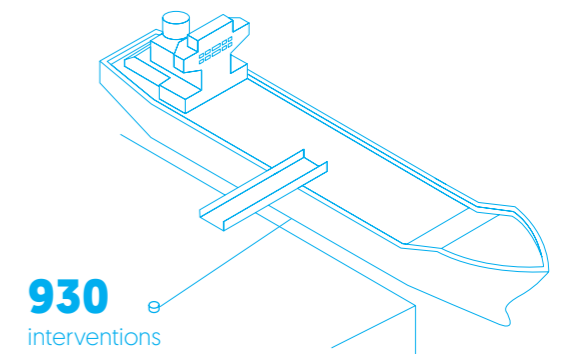

DIRECT OPERATION OF PLANT AND EQUIPMENT

In Saint Nazaire

- 97 719** tonnes of cargo handled during
- 64** port calls
- 64** various other operations

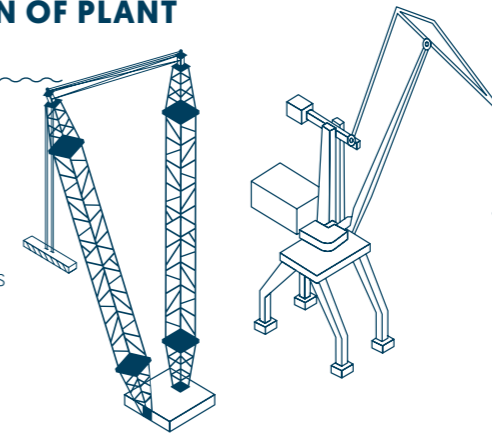

In the Upriver Facilities, by Subsidiary Company Nantes Port Terminal (excluding the Roche Maurice grain terminal)

- 301 937** tonnes of cargo handled during
- 65** port calls
- 25** various other operations

MAINTENANCE

In hours worked, by type of customer

- 85 235** hours for Nantes – Saint Nazaire Port, or approximately 63 %
- 45 766** hours for external customers (including terminal operators), or approximately 34 %
- 3 763** hours for Nantes – Saint Nazaire Port subsidiary company Nantes Port Terminal, or approximately 3 %



PORT AUTHORITY AREA

- 508** customers
- Over **800** contracts

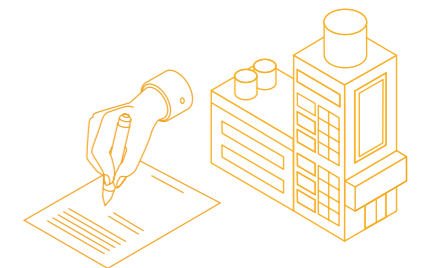

ECONOMIC AND FINANCIAL INDICATORS

Faced with major climate- and energy-related challenges, Nantes - Saint Nazaire Port is taking action to ramp up the necessary ecological and energy transitions. The Port Authority has given itself ten years in which to transform its economic model, which at present is reliant in great part on fossil-energy-generated maritime traffic. 2022 reflects that ambition, with concrete achievements being delivered and new projects being undertaken. Investments have accompanied the implementation of these actions. This year saw the activation of the growth drivers identified and presented in the 2021-2026 strategic plan, including the value enhancement of real-estate assets and the support for the deployment of new energy sources [notably the floating wind power sector].

Following the previous year, which was affected by the temporary shutdown of the TotalEnergies refinery at Donges, 2022 presented itself as a year of recovery. The changes in the geopolitical and economic context characterized by the war in Ukraine since February 2022, with notably a surge in energy prices, inflation reaching nearly 6 %, renewed supply pressures, and reduced market visibility, have required an agile response from Nantes - Saint Nazaire Port and from the Port Community as a whole, in order to take actions designed to reduce the impacts of those changes.

In 2022, Nantes - Saint Nazaire Port generated 118.6 M€ in income, a gross operating profit of 25.6 M€, and 23.4 M€ of cash flow. A profit in the amount of 2.1 M€ is thereby recorded for 2022 in the corporate financial statements of the Port Authority.

INCOME

in millions of euros	2022	2021
Port Dues	39.5	27.4
Port Property Income	29.7	26.6
Other Sources of Sales Turnover	24.7	19.8
Central Government Funding	17.4	18.8
Other Sources of Income	7.2	8.0
Income	118.6	100.6

FINANCIAL STATEMENT

in millions of euros	2022	2021
Gross Operating Profit	25.6	16.9
Operating Profit / Loss	2.4	-2.3
Financial Income Balance	-0.3	-3.1
Net Profit / Loss	2.1	-5.4



Wind turbine blades being loaded.

Nantes - Saint Nazaire Port has presented consolidated accounts for 2022, integrating its subsidiary company Nantes Port Terminal, which formerly operated the upriver port installations at Cheviré. As of 1st January 2023, this facility is now directly operated by Nantes -Saint Nazaire Port.

Nantes - Saint Nazaire Port made 29.3 M€ of investments in 2022, in line with the three growth drivers identified in its 2021-2026 strategic plan: the development of the commercial port and of existing activities, the development of renewable energy sources, and the value enhancement of Port Authority real estate.

2022 represented the second year of implementation of the long-term investment programme for the period 2021-2030, a key lever in ramping up the process of ecological and energy transition, which accompanies Nantes - Saint Nazaire Port's change of economic model.

The investment operations carried out in 2022 notably concerned the work to increase the capacity of the Montoir de Bretagne liquid cargo berth, the development of "plug & play" platforms and the construction of metal-and-textile warehouses at the Montoir de Bretagne industrial operations facility, the renewal of the port-based rail network for the development of railfreight and intermodality, studies relating to the development of an infrastructure for floating wind power in Saint Nazaire, electrification work helping to enhance the energy performance of port-related activities, and the upgrading of structures in Saint Nazaire.

The co-financing of the investment programme by Central, Regional and Local Government represented 36 % of the investment total.

THE FUNDING OF THE INVESTMENT PROGRAMME BREAKS DOWN AS FOLLOWS:



- Central Government: **4,1 M€**
- Pays de la Loire Regional Authority: **3,6 M€**
- Loire Atlantique Departmental Authority: **1,8 M€**
- Saint Nazaire Urban Area District Authority: **0,5 M€**
- European Union: **0,5 M€**
- Nantes Metropolitan District Council: **0,1 M€**
- Nantes - Saint Nazaire Port: **18,7 M€**

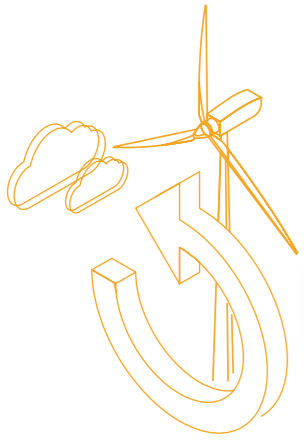

CSR REPORT



2022



MAINTAINING DIALOGUE WITH INTERESTED PARTIES

Nantes – Saint Nazaire Port operates within a complex ecosystem. Going beyond the Governance Bodies which already incorporate a broad representation of interested parties, the Port Authority maintains and nurtures a wide-ranging dialogue with industrial, logistical and port players, civil society, and institutional or industrial relations partners.

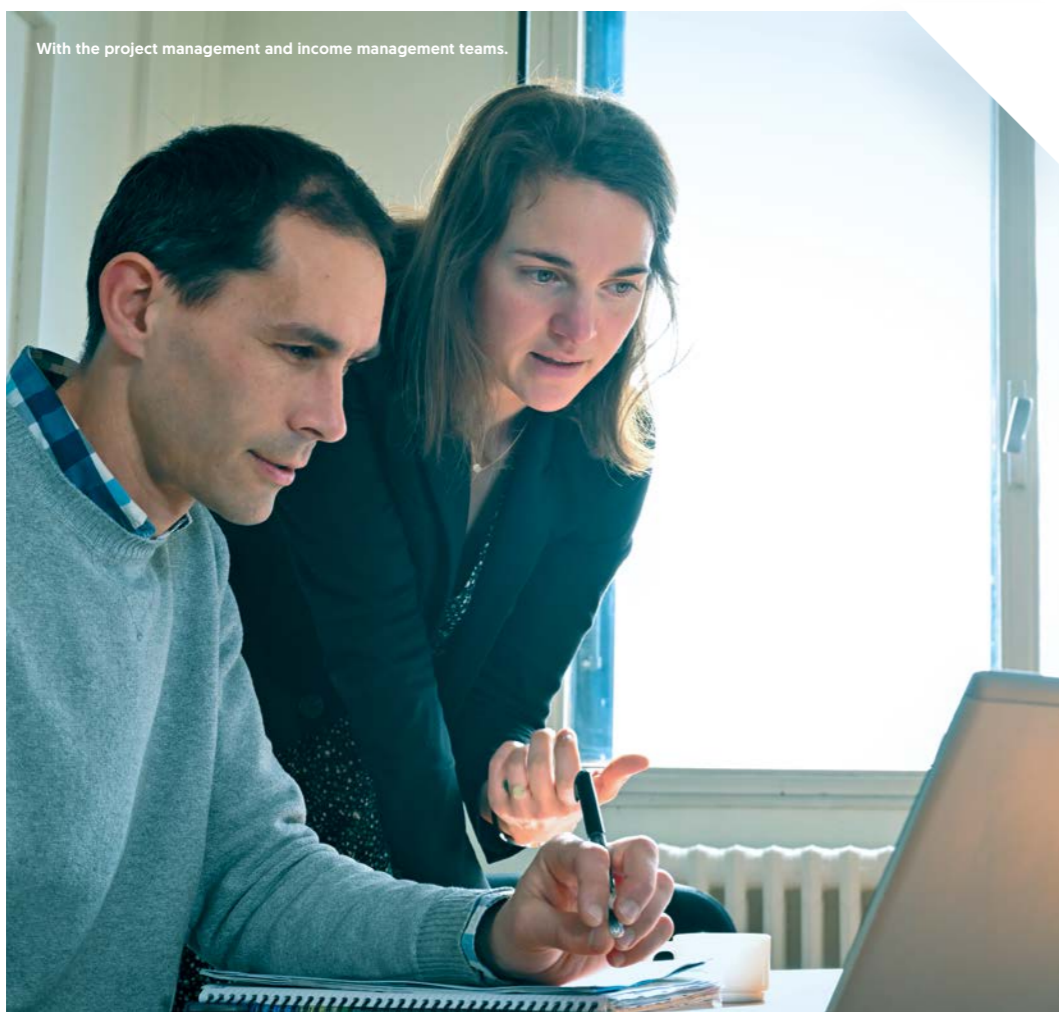

1 - Industrial Relations Dialogue

Nantes – Saint Nazaire Port ascribes great importance to industrial relations dialogue, so as to be able to rise to the challenges involved in economic, environmental or societal changes, while preserving the proper balances.

Through the intermediary of the appointed bodies, the representatives of the Port Authority's personnel are informed regarding the issues, projects and changes affecting Nantes – Saint Nazaire Port. Regular meetings are held with the Social and Economic Committee, the two Health and Safety at Work Commissions (H&SWCs), one for shore-based personnel and another for sea-going personnel, and the Local Representation Employee Delegates. Economic plans, work organization, staffing, the skills development plan, and investments are among the issues discussed by these bodies.

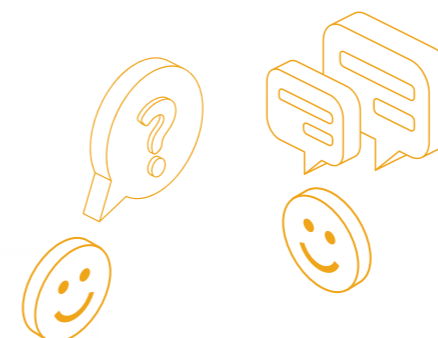

Economic and social changes also underpin the process of negotiation with the Organization's trade union representatives. Numerous topics are discussed and form the subject of collective bargaining agreements: salaries, work organization, teleworking, pre-retirement measures, etc.

Following a psychosocial risk [PSR] appraisal conducted in 2020 and in 2022 by consultancy firm Secafi at the request of the Social and Economic Committee, a programme of action has since been implemented and followed up by all Nantes – Saint Nazaire Port's Departments and Directorates, in conjunction with the Occupational Health Services, as well as with the Port Authority's own nursing and social welfare personnel. The subject is continually monitored by the H&SWCs and by a PSR Committee.

More generally speaking, the Quality & Safety Department and the Occupational Health Mission assist Nantes – Saint Nazaire Port's salaried employees as regards risk prevention in the course of their activities. The actions undertaken over a number of years, in terms of personnel training, of raising awareness, and of selecting the right personal protective equipment, are helping progressively to instil a shared safety culture. There is a lot at stake: 25 industrial accidents involving absence from work were recorded in 2022, as compared to 14 in 2021 and 11 in 2020, thereby marking a return to the levels last seen before the COVID-19 pandemic. A programme of action involving the members of the various representative bodies and the salaried employees aims to tackle this accidentology issue.

2 - Economic and Institutional Players

As an industrial tool for economic growth and a regional planner and developer, Nantes – Saint Nazaire Port maintains close links with the Region Community's players. Partnership actions associating Regional and Local Government, Central Government Departments, businesses and industrial firms, and consular organizations, are regularly undertaken to boost economic sectors in Greater Western France.

2022 saw the relaunch of a Greater Western France port promotion dynamic, to go out and capture new markets. The participation in several key trade shows in the transport and logistics or new energy sectors was thereby programmed on a collective basis.

The SITL Transport and Logistics Innovation Week event was held in Paris, from 5th to 8th April. Created in 1983, this annual trade show is the unmissable event for the transport and logistics markets. The 2022 edition brought together on a joint stand Nantes - Saint Nazaire Port, Compagnie Ligérienne de Transport, Sea-Invest France, SNM, Somaloir and UMNP Nantes Ports Maritime Union. Over the course of four days, the professionals present were able to speak with Nantes - Saint Nazaire Port's teams and with managers from port firms based on the Loire Estuary, to find out more about various offers and proposals, notably as regards logistics, warehousing, major industrial projects, and maritime solutions.



On the stand at the SITL Trade Show, in Paris.

From 17th to 19th May, the Ahoy Complex in Rotterdam (Netherlands) played host to the Breakbulk Europe Trade Show, an unmissable international event when it comes to talking to professionals in the dry bulk cargo and *project cargo* traffic sectors. Nantes - Saint Nazaire Port, Sea-Invest, Somaloir and Terminal du Grand Ouest [TGO] were all present on a joint stand to showcase the know-how possessed on the Loire Estuary in terms of breakbulk and heavy-lift cargo in the aeronautical, marine craft, forest products and other industrial sectors.

After a four-year-long absence, the key international trade show dedicated to the forest products sector made its return to the La Beaujoire Exhibition Centre in Nantes during the first three days of June. A long-awaited, very well attended edition. The figures put together by Fibois Pays de la Loire, the organizer of this event, which is unique in Europe, recorded 607 exhibitors from 40 different countries, all forest products professionals, and a total of 14 000 visitors, or 20 % more than for the last edition in 2018. A co-founder of this trade show, Nantes - Saint Nazaire Port welcomed a large number of contacts to a stand that it shared with representatives of the Fauveder Group on 1st June and with the Bolloré Logistics team on the following day.

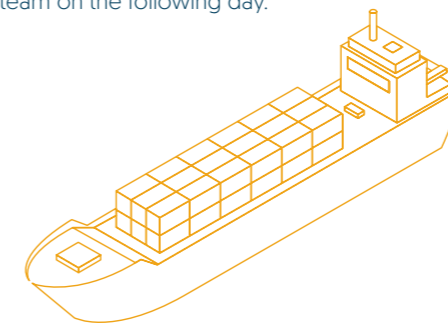

Organized by Bluesign, the Seanergy International Forum devoted to marine energy was held in Le Havre, from 15th to 17th June. The event presents and brings together sectors of activity that take in offshore fixed-foundation and floating wind turbines, tidal energy, floating photovoltaic technology... as well as related sectors such as energy storage, digital technology, wind- or hydrogen-powered low-carbon maritime transportation, drones or eco-designed materials. Seanergy attracted over 3 500 international participants, who included political representatives, energy companies and industrial firms, technological experts, investors and subcontractors, to an exhibition space in which more than 250 exhibitors from around the world were gathered. On 15th and 16th June, on their own stand, Nantes - Saint Nazaire Port's teams presented the experience gained from the process of installing France's first offshore wind farm facility, as well as the Éole project to anticipate the needs of industrial firms as regards the floating wind farms of the future, and the solutions and know-how available in terms of the port-based logistics for industrial heavy-lift cargo consignments.

From 28th to 30th June, Marseille was the venue for the Euro-Mediterranean Marine Industry and Blue Growth Trade Show. Held every two years, this event brings together professionals from the shipbuilding, ports, shipping and marine sectors. Nantes - Saint Nazaire Port presented the offers available in the areas of ship repair, shipbuilding and industrial projects, on a stand shared with Néopolia, Pays de la Loire Regional Authority, and companies ATS, Soliso, Almet, Serviloire, Ship ST, Proconnect, Mapac, Kent, Axima, Merré, CT-Arco & CNI.

Nantes - Saint Nazaire Port took part in International Week, an event organized by the Pays de la Loire Chamber of Commerce and Industry, in Angers on 27th September and in Nantes two days later. The purpose of the event was to offer companies and firms in the Pays de la Loire Region assistance in their international development.

At the Antwerp XL Trade Show, from 4th to 6th October, teams from Nantes - Saint Nazaire Port and Somaloir met with the leading ro-ro and breakbulk shipping lines as well as with freight forwarders specializing in project cargo. The emphasis was placed on the advantages possessed by the Loire Estuary Port Community: no port congestion, availability of storage areas, and recent investment in rail infrastructures.



During Season 2 of the Smart Port Hackathon.

Oportunity, the new identity of Greater Western France's port promotion collective, was unveiled at a launch event held in the evening of Thursday, 13th October, in the presence of over 120 Nantes - Saint Nazaire Port Community players. Instituted in 2018, Nantes - Saint Nazaire's port promotion initiative is thereby given fresh impetus. In order to develop, the Port of Nantes - Saint Nazaire has to play as a team, to demonstrate agility, and to make its port services and logistics offer visible. The collective comprises Nantes Ports Maritime Union (UMNP), Nantes - Saint Nazaire Chamber of Commerce and Industry, Pays de la Loire Regional Authority, Saint Nazaire Urban Area District Authority, Nantes Metropolitan District Council, Loire Atlantique Departmental Authority, and Nantes - Saint Nazaire Port. A programme of action that pools all the Port Community's expertise has been initiated. The first stage of the **Oportunity** Roadshow, the purpose of which is collectively to go out and meet shippers across Greater Western France, took place in Angers, on 13th December. 100 representatives of firms and companies in the Department of Maine et Loire wishing to develop or to launch their activities internationally accepted the invitation from the port promotion collective to discuss the topic of the sustainable and responsible globalization solutions available to businesses.

To promote the offer internationally, the members of **Oportunity** are also participating in trade missions abroad. A first visit was made to Scandinavia, in November, on the initiative of Pays de la Loire Regional Authority. The delegation visited the Ports of Gävle and Stockholm in Sweden, Oslo in Norway, and Esbjerg and Copenhagen in Denmark. The participants also met with Scandinavian industrial firms to discuss subjects including the decarbonization of ports, wind power (principally offshore), the electrification of quays and handling equipment, the capture of CO₂ or e-fuels, all of which resonate with the commitment of the Nantes - Saint Nazaire Regional Community's port and institutional players to energy transition.



During the launch of Oportunity, Greater Western France's port promotion collective.

The second Smart Port Hackathon organized by Nantes - Saint Nazaire Port took place on 22nd, 23rd and 24th November 2022 at the Halle 6 Technology Centre in Nantes. Over 100 participants were there to take up one of five proposed challenges: how to value-enhance Nantes - Saint Nazaire Port's property development and real-estate offer within a dynamic Regional Community, how to understand the dynamics of the energy transition process being driven by Nantes - Saint Nazaire Port and its partners, how to use digital technology to serve the Port Community's circular economy, how to orchestrate and to optimize transport operations and logistical flows in the Port Authority area, and how to create the digital community of Nantes - Saint Nazaire Port's salaried employees. Each project is set to move forward so as to arrive at digital solutions. A new development season therefore opened right at the start of 2023, with the creation of post-Hackathon workshops. Going beyond the proposed solutions, which will be further explored and developed, the Smart Port Hackathon demonstrated once again that, through this collective intelligence of different, engaged and enthusiastic constituencies, Nantes - Saint Nazaire

Port obtains real, concrete solutions that are going to contribute to its innovative thinking and appeal in crucial areas. This event is now integral to the Loire Estuary Regional Community landscape, as a meaningful gathering of many minds.

Finally, Nantes - Saint Nazaire Port contributes to the work of the Pôle Mer Bretagne Atlantique Brittany-Atlantic Region Maritime Cluster (PMBA). The Port Authority makes available one staff member on a part-time basis to assist the "Ports, Infrastructures and Shipping" strategic action team. The PMBA held several events in 2022, which included a "Hydrogen" workshop at the Pays de Loire Regional Authority headquarters on 8th December, and a major "Blue Event" on the topic of port safety, at the Idéa Group's Montoir de Bretagne premises on 19th May, in partnership with Nantes - Saint Nazaire Port and the port terminal operators. The Port Authority also participated in the Port of the Future Forum, which was organized by CEREMA (the Centre for Studies and Expertise on Risks, the Environment, Mobility, and Development), and took place in Lorient on 4th and 5th October.

3 - Environmental Interest Groups and the Scientific Community

For several years now, a regular dialogue has been maintained with a number of environmental interest groups, in particular Bretagne Vivante [Living Brittany], France Nature Environnement [France Nature & Environment], the French National Society for the Protection of Birds, and Estuaires Loire et Vilaine [Loire & Vilaine Estuaries]. These discussions make it possible to share concerns regarding the various issues facing the Loire Estuary and to explain the approaches that are being considered. Living Brittany, France Nature & Environment, and the French National Society for the Protection of Birds are all represented on Nantes - Saint Nazaire Port's Development Board.

As a member of the Maritime Council for the Northern Atlantic Seaboard – Western Channel Range, Nantes - Saint Nazaire Port helps to define the objectives and the action plan associated with the Seaboard Environment Strategy [SES], which was adopted in September 2019. Serving an integrated maritime policy, the SES rolls out the National Sea and Coastal Areas Strategy and two EU Directives relating to the attainment of good ecological status for the marine environment and to the planning of uses of the sea and activities at sea. Elaborated jointly with elected representatives and socio-economic players from the Regions of Brittany and Pays de la Loire, gathered together within the framework of the Maritime Seaboard Council, the SES action plan was adopted on 6th May 2022. The plan provides for 114 actions to promote blue growth and the ecological transition of maritime activities, and to ensure the protection of the marine environment.

At its 19th plenary meeting held on 11th July at Nantes - Saint Nazaire Port's headquarters, the Maritime Council for the Northern Atlantic Seaboard – Western Channel Range notably discussed the national strategy for marine protected areas and the plan to create a maritime seaboard scientific board. Having reached the end of its term of office on 7th November, the Maritime Seaboard Council saw the composition and appointment of its membership renewed by interprefectoral orders signed on 15th December 2022.

Nantes – Saint Nazaire Port also sits on the Executive Committee of the Local Water Management Commission of the Water Planning and Management Scheme [SAGE] for the Loire Estuary. This Commission brings together all the parties concerned by water issues, including elected representatives, users [farmers, industrialists, environmental interest groups, consumers, etc.] and Central Government agencies. It validates the different stages in the elaboration of the SAGE and, via opinions presented to the Regional Prefect, monitors the status of applications for authorizations under the provisions of the Water Quality Act. The Executive Committee of the Local Water Management Commission met on 13 occasions in the course of 2022.

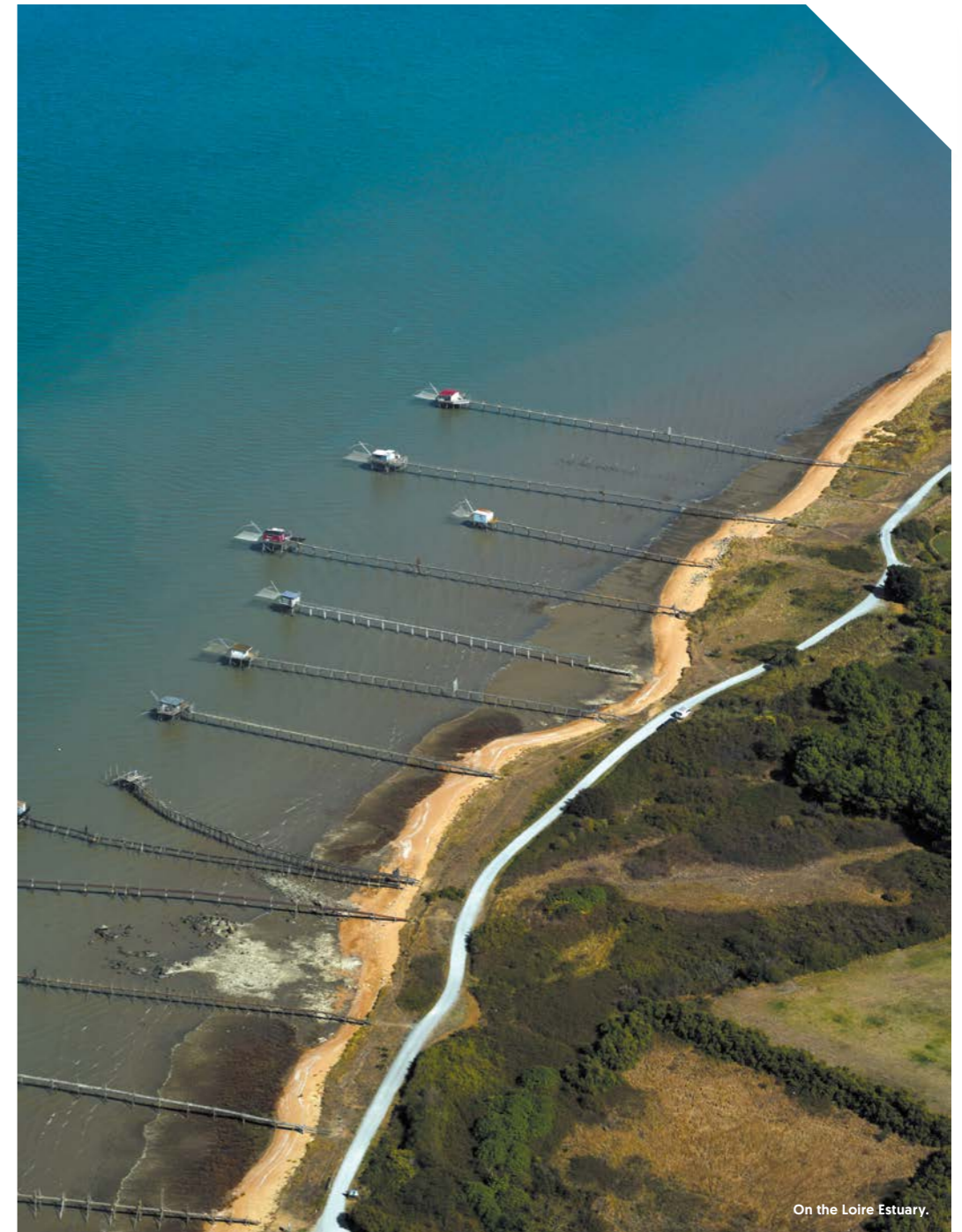

On the Loire Estuary.

4 - Connecting with the Community and the General Public

Nantes - Saint Nazaire Port is pursuing its efforts to be better known to the general public as a whole, and notably to the citizens of the Loire Estuary. The Port Authority is developing its presence on digital media, and regularly opens its doors to all kinds of visitors, offering access behind the scenes of its activities.

Since 2021, Nantes - Saint Nazaire Port has offered members of the public the chance find out in a fun way about the leading port on France's Atlantic Seaboard. Developed by the Nantes-based company Baludik, the "Du côté du port" ["Portside"] app already proposed two pathways for visitors, in Saint Nazaire and in Nantes respectively. In April 2022, the Port Authority added a third discovery pathway running alongside the Loire Estuary, which is entitled "A Bird's Eye View of the

Estuary" and is available via the Baludik app. The user is guided by Plum', an aquatic warbler, the migratory bird that is emblematic of the Estuary. Plum' flies over the Loire and invites the user to go on a digital treasure hunt to discover a whole series of places, such as the industrial giants observation post at Corsept, the Canal de la Martinière canal, the site of Port Lavigne at Bouguenais and some surprising locations that are little known to the general public, such as the Cale des Carris route in the District of Le Pellerin. Co-designed by Nantes - Saint Nazaire Port and Baludik's developers, a new feature has been incorporated in the third pathway. Based on augmented reality, it asks the user to scan vessels that are alongside quay or moving along the Loire, to find out about their dimensions, origin, and destination.



Students meet the teams at the Montoir de Bretagne maintenance workshop, as part of the Regional Education Pact programme.

After LinkedIn, Facebook and Twitter, Nantes - Saint Nazaire Port joined Instagram in May. This social network, which gives pride of place to attractive photographic images, serves to showcase the specialisms and the life of the Port in a new way. In total, Nantes - Saint Nazaire Port has over 13600 subscribers to its social media accounts.

On 27th and 28th October, as part of the 7th edition of the Pays de la Loire Region's "Company Tours in Our Region Days" initiative, Nantes - Saint Nazaire Port gave visitors the opportunity to meet port professionals in locations that are usually closed to the public. They were able to discover the Harbour Master's Office, the central command station for the Saint Nazaire locks or the Loire Pilots Association navigation simulator. Involved ever since the very first edition of this event, Nantes - Saint Nazaire Port has enabled more than 500 visitors to benefit from these encounters and to step behind the scenes of the port environment.

For the fourth consecutive year, Nantes - Saint Nazaire Port joined in the Pays de la Loire Regional Education Pact programme, which supports the success and professional inclusion of young high school students and apprentices. As part of this programme, over sixty students receiving primary vocational training in logistics, nautical maintenance and industrial metal fabrication were able to discover the richness of the whole port and industrial complex by talking to those who work there. The visits are organized in partnership with Saint Nazaire Renversante [Saint Nazaire Tourism], the Visit Our Businesses in Pays de la Loire Association, and the Pays de la Loire Chambre of Commerce and Industry.

From 21st August to 8th September, Nantes - Saint Nazaire Port was a partner of the 53rd edition of the Solitaire du Figaro single-handed yacht race. Present at the heart of the village, for the departure and for the arrival of the race, Nantes - Saint Nazaire Port personnel were able to interact with members of the public and discuss the Port's activities.



The presentation of the Nantes "Portside" discovery pathway on the Baludik app.

WORKING TO SUPPORT EMPLOYMENT AND PROFESSIONAL EQUALITY

The activities at the Port of Nantes – Saint Nazaire generate 28 500 jobs¹ in Greater Western France. The jobs that are directly created include the salaried employment at Nantes - Saint Nazaire Port and at the numerous organizations involved in receiving vessels and processing cargo consignments (cargo handling, warehousing, trading activities, vessel piloting, tugging, inshore piloting, brokerage, etc.), or more than 9000 maritime and port professionals in total. Other indirect jobs derive from these activities. This is the case in the aeronautical, automotive, energy, agri-food or transport sectors. These

direct and indirect jobs in turn have an impact on the subdivisions forming the Port Authority area and on the districts in which these salaried employees live, serving to support or to create spin-off jobs.

As of 31st December 2022, Nantes – Saint Nazaire Port employed 604 permanent salaried personnel, 20 % of whom are women and 80 % are men. 58 new staff members joined Nantes - Saint Nazaire Port during the year. The Port Authority encourages internal mobility, with nearly 35 % of vacancies for shore-based and sea-going personnel taken together having been filled in this way.

80 different specialisms are represented within the Organization, enabling Nantes – Saint Nazaire Port to fulfil all its missions. Rolled out on an annual basis, the skills development plan assists the salaried employees in adapting their skill sets in the light of the regulatory, technical and digital changes impacting those various specialisms, and supports internal mobility on a vocational level. The emergence of new specialisms connected with the strategic plan is also taken into account. In 2022, Nantes - Saint Nazaire Port devoted 3.9 % of the total gross remuneration to vocational training, and 66 % of the salaried employees completed at least one training course. Being particularly involved in the transformation of Nantes - Saint Nazaire Port's economic model, management personnel have been able to benefit from an executive training programme stretching over six months, which was launched at the end of 2022.

Back in 1998, in creating a dedicated inclusion unit the Port Authority made a commitment in favour of the social and professional inclusion or reintegration of persons excluded from the workplace. Recruited under assisted employment contracts, the inclusion unit team comprises 4 to 6 employees depending on the time of year. Each is given a 12-month contract with a renewal clause, in order to develop new skills with a view to reintegrating the world of work more easily. The activities to which the team is assigned are chosen according to their educational value. The different work situations encountered permit each employee to develop skills that are useful and transferable to other companies. Following their experience with Nantes – Saint Nazaire Port, around 7 employees in 10 find another job or engage in vocational training leading to a qualification.

Committed for several years now to receiving trainees and interns, Nantes - Saint Nazaire Port has chosen over the past two years to reinforce that support. In this way, each year young people on block-release courses or seeking internships join Nantes - Saint Nazaire Port to receive training in the Port's specialisms, notably in mechanical engineering, metal fabrication, industrial engineering, human resources, communication, quality, safety and environment. In 2022, 20 block-release trainees and 70 interns were received by the Port Authority.

8 years ago now, Nantes – Saint Nazaire Port embarked on an initiative in support of the professional inclusion and the maintenance in employment of disabled workers. The Port Authority made a commitment to promote the integration of all employee profiles without discrimination (adaptation of the procedures for the recruitment and inclusion of disabled workers), to safeguard career paths (identification, establishment and monitoring of maintenance-in-employment and redeployment situations), and to develop partnerships with local players so as to professionalize practices (recruitment, maintenance in employment and subcontracting with the protected sector). In 2022, the rate of employment of individuals with a recognized disability represented 5.4 % of the overall headcount (compared to 2.5 % in 2015).

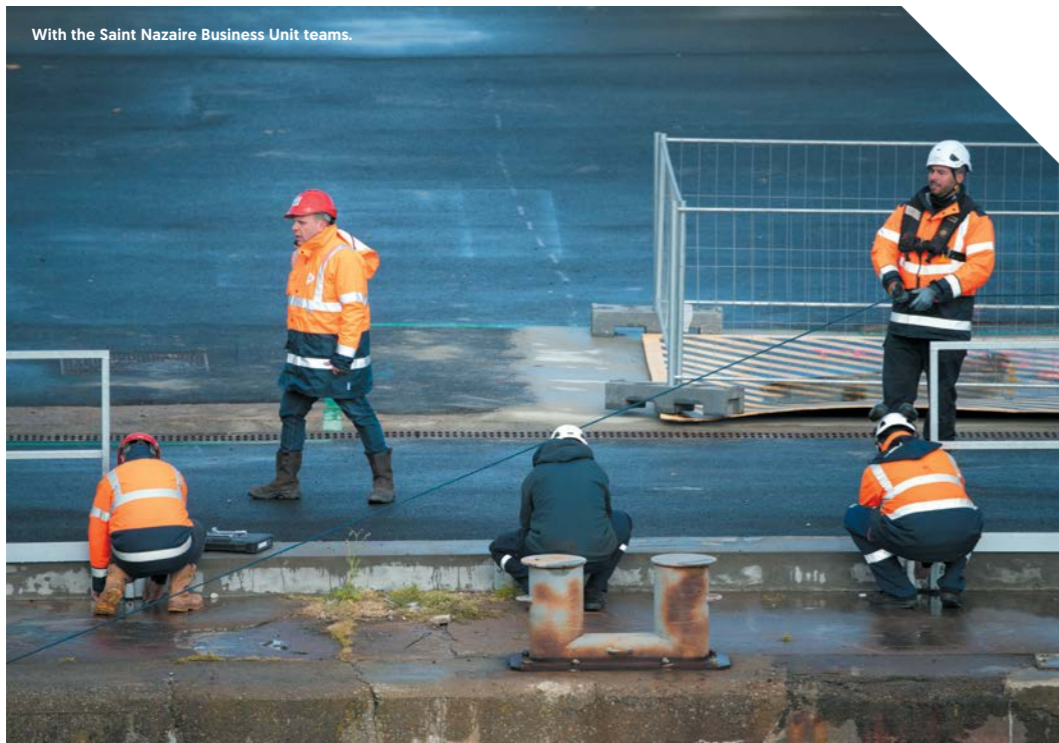

¹ INSEE (French National Institute of Economic and Statistical Information) - 2022 study based on 2018 data

ACTING TO ADVANCE ENERGY TRANSITION

Nantes - Saint Nazaire Port's commitment to the cause of energy transition naturally means actively participating in the development of the marine renewable energy sector. The necessary acceleration of that process of transition also encourages experimentation with and the accommodation of new energy solutions within the Port Authority area.

Initiated by the City and State of Hamburg within the framework of the European Union's Interreg Europe Programme, the *Smooth Ports* project aims to identify solutions to reduce CO₂ emissions from road traffic at ports. Launched in 2019, the project brings together six European partners, including Nantes - Saint Nazaire Port. The *Smooth Ports Project* presented its results at a final seminar held in Brussels on 13th and 14th September 2022, before a forty-strong group of participants. The challenges posed by sustainable port development are expressed notably in terms of the reduction of in-port vessel emissions, the smart management of road traffic, or digitalization.

A first **7.6 MW**
photovoltaic power plant comprising
14 000 solar panels

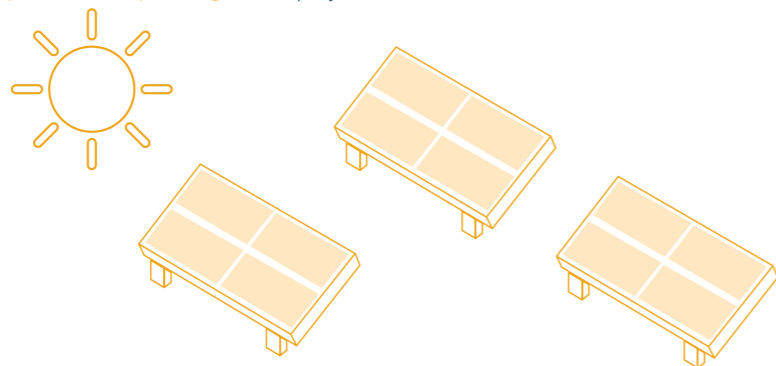

Unoccupied up to now, 22 hectares of land whose use is restricted under the Montoir de Bretagne technological risk prevention plan (TRPP) will be utilized to accommodate two photovoltaic power plants. The installation of the first plant, sited to the east and north of the Montoir de Bretagne LNG terminal, was completed at the end 2022, after eleven months of work. With its 14 000 ground-level solar panels covering a 9-hectare surface area, this photovoltaic power plant came into service in January 2023 and is operated by Engie Green. It will permit the production of 7.6 MW of electricity, equivalent to the level of consumption of 4 200 people.

Following a call for expressions of interest issued in the spring of 2022, in July Nantes - Saint Nazaire Port signed an agreement with Amarenco for the installation of a second, 13.9-hectare ground-level solar farm, to be located to the west of the Montoir de Bretagne LNG terminal. The expected output is approximately 13 MW of electricity, or the equivalent of the annual electricity consumption of 2 860 French households. The installation is scheduled to be commissioned at the end of 2025. Amarenco will also be studying the opportunity to develop battery storage units in proximity to the future photovoltaic power plant and on the land made available for the project.

Hydrogen is already benefitting from strong momentum, driven by the national strategy for the development of low-carbon hydrogen in France, and as will offshore wind power, this energy source will be called upon to occupy an increasingly important place in the French and European energy mix. Aware of the potential of this new energy source, the Port Authority is studying the scenarios for the deployment of the hydrogen sector within its ecosystem. With this in mind, at the end of November Nantes - Saint Nazaire Port issued a call for expressions of interest, with real estate to be made available for a hydrogen production and distribution project within the Port Authority area. In this way, a 12-hectare site located to the north of the Montoir de Bretagne multi-bulk terminal could accommodate a project to establish a facility for the industrial production and distribution of renewable or low-carbon hydrogen and derived e-fuels. A pre-selection of candidates is expected in 2023.

In November, Nantes - Saint Nazaire Port signed a partnership agreement with Lhyfe, one of the world's pioneers for the production of green, renewable hydrogen, with a view to understanding and assessing the conditions for the establishment of a supply chain associated with offshore hydrogen production. In addition, at the end of September in the Saint Nazaire dock basins, Lhyfe launched its Sealhyfe project to deliver the world's first offshore renewable hydrogen production prototype, which will have a capacity of 1 MW and will be connected to a floating wind turbine.



At the Engie Green solar farm in Montoir de Bretagne.

Together with its industrial and institutional partners, Nantes - Saint Nazaire Port is now on a trajectory to develop a low-carbon industrial activity zone (ZIBaC). On 15th November, the Loire Estuary Association of Industrial Firms (AILE), Saint Nazaire Urban Area District Authority, Estuaire et Sillon Community District Authority and Nantes - Saint Nazaire Port submitted an application in response to the call for proposals by ADEME (the French National Agency for Energy Transition) for a low-carbon industrial activity zone (ZIBaC). Through this call for proposals, the aim is for Central Government to assist industrial communities in their ecological and energy transformation, so as to boost their competitiveness and their appeal, and thereby support economic recovery. A joint goal and a common roadmap have been elaborated, with the threefold objective of achieving carbon neutrality in the port activity zone by 2050, of delivering industrial resilience in the face of the predictable consequences of climate change, and of encouraging the emergence of new sectors underpinning energy transition. Some twenty proposals have been presented as part of the application. Low-carbon industrial activity zone certification [ZIBaC certification] would secure funding to turn many of those proposals into a reality.

Nantes - Saint Nazaire Port
is now on a trajectory to develop
a **low-carbon industrial activity zone**

ZIBaC



On another scale, Nantes - Saint Nazaire Port has committed to reducing the energy impact of its activities day to day, by elaborating and expanding an energy sobriety plan. Part of the efforts that public-sector establishments on a national level are requested to make, to achieve a 10 % energy saving today compared to 2019 and a 40 % energy saving by 2050, this initiative requires detailed knowledge of the energy consumption of Nantes - Saint Nazaire Port's assets (including buildings, plant and equipment, port-based craft and vessels, vehicles, structures...), knowledge that is being consolidated. This should lead to the identification of the main levers for reducing consumption, permitting the effective management and anticipation of expenses and the prioritization of refurbishment and maintenance work. Certain straightforward measures have already been instituted, such as reducing the navigation speed of the dredger *Samuel de Champlain*, the replacement of boilers, the adoption of the auto sleep mode for all office equipment, and raising the awareness of the salaried employees regarding eco-friendly gestures.

Lastly, confronted by the energy crisis, Nantes - Saint Nazaire Port has subscribed to the Ecowatt Charter introduced by Electricity Transmission Network RTE and ADEME. This scheme aims to encourage the community-minded mobilization of French citizens, agencies of government, businesses and associations in the interests of responsible electricity consumption. In this way, Nantes - Saint Nazaire Port has undertaken to adapt its energy needs during periods of peak consumption and at the most opportune times, in the event of stresses on the electricity system.



The Montoir de Bretagne port facilities.

MANAGING THE LOIRE ESTUARY'S NATURAL SPACES

Out of a Port Authority area that covers 2722 hectares, Nantes - Saint Nazaire Port manages 1177 hectares of natural spaces. Via its 2021-2026 strategic plan, the Port Authority is implementing a policy of restraint: as all its real-estate reserves are already artificialized, Nantes - Saint Nazaire Port does not consume any natural spaces for its economic development. The Port Authority therefore acts in compliance with the provisions of the National Biodiversity Plan, of the 2020 National Low Carbon Strategy, and of the French Act of Parliament dated 22nd August 2021, which lays down the principle of "Zero Net Artificialization".

Since 2017, Nantes - Saint Nazaire Port has been implementing a plan to manage the natural spaces at East Donges, which represent a surface area of 460 hectares. Characterized by extensive reedy marshes, wet meadowland, temporary pools, and sandy deposits, the site is home to numerous species of birds, amphibians and insects. This management tool was elaborated in consultation with all the stakeholders, both locally (hunters, farmers, environmental associations) and at Estuary level, in order to preserve or even to increase biodiversity while also striking a balance with the different uses made of the site. The plan covers six major issues: biodiversity, agriculture, hunting, knowledge, communication-accessibility and governance. In total, 24 operational goals and 27 action memoranda have been defined for the period 2016-2025. In 2022, as prescribed in the management plan, Nantes - Saint Nazaire Port commissioned Artélia, an independent research consultancy, to conduct an appraisal midway through the programme. This first assessment

served to evaluate the efficiency and effectiveness of the work carried out from 2017 to 2021, to judge to what extent the goals have been attained, and to define the prospects for the management plan until 2025. The methodology employed ascribes a score for each criterion: execution, timing, and technical means. The overall average for the execution of the management plan at the halfway point is 86 %. The long-term prospects of the management plan remain the same; Artélia recommended that ten of the initial 27 action memoranda be revised, however. Nantes - Saint Nazaire Port conducted ecological inventories on the site in 2023, so as to update the initial appraisal carried out in 2013 and 2014. The findings of this expert survey will make it possible to determine whether or not the biodiversity challenges at East Donges have evolved. The new natural space status of the 120-hectare Le Locherais site, north of the zone, could bring about changes in terms of the biodiversity challenges for natural spaces that now cover a larger area.

Nantes - Saint Nazaire Port manages **1177 hectares** of natural spaces.



In the heart of a reedy marsh, on the Loire Estuary.

ACROLA, the Loire and Atlantic Association for Ornithological Knowledge and Research, is a key player in the East Donges management plan. Supported for nearly 20 years now by Nantes - Saint Nazaire Port, ACROLA conducts bird-ringing operations in the reedy marshes of East Donges. The results show that the site is one of France's three largest staging areas on the migration routes of certain species of passerines. The East Donges bird-ringing station notably plays a prominent role in the conservation of the aquatic warbler, which is one of the most threatened species in Europe. Nationally speaking, it is on the East Donges site that the most individual birds are captured. The station is located on the route taken by most of the species concerned during their postnuptial migration. The findings illustrate the close relationship between East Donges and the coastal Departments in the North and West of France, but also as regards a number of countries in Europe and Africa. ACROLA carried out a new bird-ringing operation on a daily basis between 20th July and 28th October 2022. The 18 451 captures that were made comprised 15 629 individual birds, including 15 180 ringed birds, and 62 different species.

On a like-for-like basis, that represents an increase of 20.5 % compared to 2021. On the basis of like-for-like protocols and time frames, for the principal species concerned ACROLA observed a 16 % increase in the number of sedge warblers, and a 44 % rise in the number of Eurasian reed warblers. The number of aquatic warblers has doubled, thereby recording the best outcome since the start of the monitoring process. This appears to reflect the resilience of the species, following a drop in numbers due to the fire-induced destruction of breeding sites.

Nantes - Saint Nazaire Port charged research consultancy SEGED with the task of updating throughout 2022 the ecological inventories for the Le Carnet site. The inventories were carried out over the entire 395-hectare area. Following 95 days of field survey work to that end, the findings confirmed the richness and diversity of the site's natural heritage, and in particular in terms of flora, natural habitats, birds, and amphibians. The report recorded 33 key natural habitats and 107 key species.

CSR INDICATORS

EMPLOYMENT

The activities at the Port of Nantes – Saint Nazaire generate

28 500 jobs*

*2022 study by INSEE, the French National Institute of Economic and Statistical Information, based on 2018 data.



9 000 maritime and port-based jobs

which

19 500 industrial and service sector jobs



In 2022, Nantes – Saint Nazaire Port placed orders for services with **553 companies**

in the Pays de la Loire Region, representing a total of **23 million euros**

HEADCOUNT

Nantes – Saint Nazaire Port has **604 salaried employees**



484 men

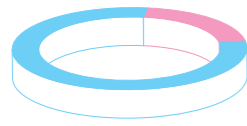

120 women
20% of personnel are women



The average age is nearly **46 years**



5.6 % of the personnel are classified as disabled

TRAINING



3.9 % of the total gross remuneration is devoted to vocational training

34 % of the vocational training budget is dedicated to safety.



CERTIFICATION



ISO 9001



Ecoports Label



Mase
[Safety Improvement in the Company Environment]

WASTE RECOVERY

65 % of Nantes – Saint Nazaire Port's waste products are recovered:



87 % as compost

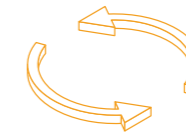

12 % as materials



1 % via energy recovery

BIODIVERSITY

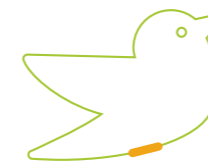

15 629 birds

recorded during the ringing operation conducted by ACROLA at Donges from July to October 2022, including **130 aquatic warblers**.



During a wind turbine nacelle loading operation, in Saint Nazaire.



Nantes – Saint Nazaire Port's 2022 Annual Report and CSR Report are also available at www.nantes.port.fr in French, English and Spanish

 nantes.port.fr/fr/medias/rapport-annuel

 nantes.port.fr/en/media/annual-report

 nantes.port.fr/es/medios-de-comunicacion/declaracion-anual

Designed and written by: Nantes – Saint Nazaire Port.

Photos: Franck Badaire, Région des Pays de la Loire except specific mentions

Created and produced by: Peppermint Agency | print and digital strategy agency | Nantes | 02 72 02 65 73

English translation: Peter Wynne Griffiths, Official Translator at the Court of Appeal In Lyon, France.

Non-contractual document. © Nantes – Saint Nazaire Port, 2022

Printed on PEFC paper using vegetable-based inks by Calligraphy Print (35)



NANTES.PORT.FR

